

OLIGHT

USER MANUAL

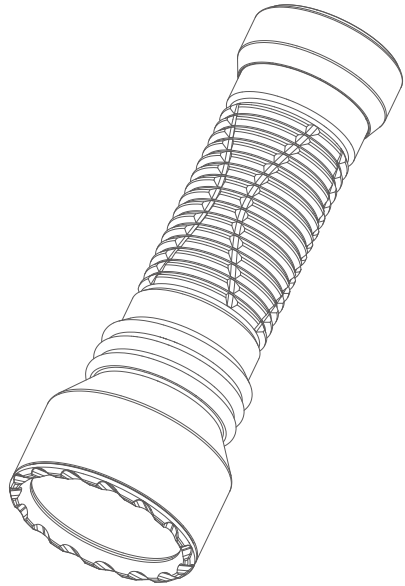

Javelot Mini

Thank you for purchasing this Olight product. Please read this manual carefully before use and keep it for future reference!

IN THE BOX

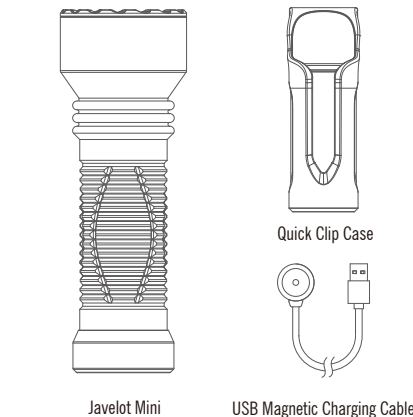

SPECIFICATIONS

HIGH
1000 lumens
100% 6.5min ~ 50% 78min ~ 20% 19min

LOW
200 lumens
100% 4h57min

88,320cd 600m IPX8 1.5m

154g / 5.43oz (Including Battery) (L)115*(D)40mm (L)4.53*(D)1.57in Working Temperature: 0-40°C

All above specifications are test results based on ANSI/NEMA FL1-2009 Standard. The tests are performed using the battery included in the flashlight.

USB MAGNETIC CHARGING CABLE -- MCC1A

| Parameter | Specification |
|----------------------------------|--|
| Charging cable | USB type A - magnetic charging connector, length: 0.5m |
| Input | USB A - Type DC 5V 1A |
| Charging pattern | CC&CV |
| Maximum charging current | 1A |
| Voltage of fully charged battery | 4.2V±0.05V |
| Time to fully charge | 3.1 hours (For reference only) |
| Charge indication | Red: charging Green: full or disconnected with flashlight |

PRODUCT OVERVIEW

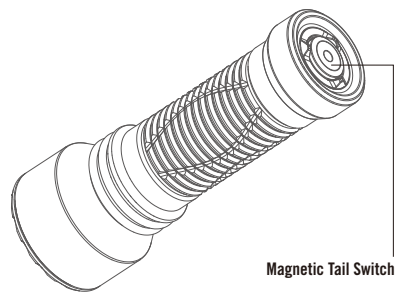

BEFORE FIRST USE

Please remove the protective film on the lens; and please also unscrew the tailcap to remove the insulating film within the battery compartment, then screw the tailcap back on tightly. If the battery needs to be replaced, make sure that the positive end of the new battery faces the flashlight head when you put it in.

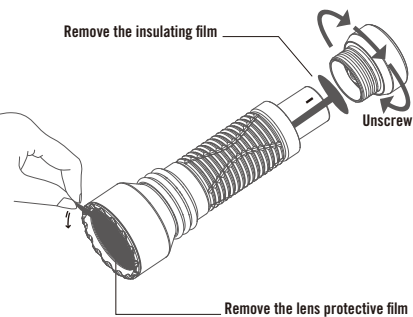

CHARGING

VIBRATING POWER INDICATOR

Alerting you if the battery is low: power < 30% vibrate once every 5 minutes; power < 10% vibrate twice per minute; power < 5% vibrate three times every 10 seconds.

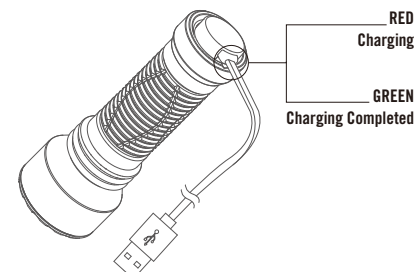

* Before first use please fully charge the product.

* Connect the USB end of the magnetic charging cable to an external USB power source, then attach the other end of the cable to the charging port of the light (best charging efficiency with a USB power source of no less than 5W (5V 1A) . The red indicator means charging, while the green indicator means charging completed.



WARNING

- Do not use damaged, deformed battery, or with broke sleeve.
- Do not short the charging port with metallic object intentionally.
- Keep the battery removed properly, don't store the battery together with metallic objects such as coins, or screws.

CAUTION

- Do not look directly at the light source or shine to eyes, may cause temporary blindness or permanent damage to the eyes.
- Do not block the light outlet at close range, the energy emitted from the light may cause the object to burn.
- Do not charge the light with any other non-specified chargers.
- Do not leave the light in a car where the inside of temperature may be over 60 C, or in similar places.
- Dedicated battery, do not take it out for charging.
- CAUTION HOT: Do not touch the hot surface place, it may cause skin burns.

REMARK

- Fully charge the battery before storing the light for a long period of time.
- Keep the charging port clean and dry.
- When the battery voltage is low, it can drive the maximum 200 lumens.
- At the ambient temperature of 25°C, the output is maintained at 1000 lumens for 5 minutes, and then slowly step down to 500 lumens within 1.5 minutes.

NOTICE

- Do not put a hot light into any type of fabric bag or fusible plastic container.
- Active thermal management: The built-in thermister monitors the temperature of the light in real time and suppresses overheating by reducing the output
- Do not short-circuit the charging port with the metallic objects.
- Do not disassemble the product.
- Do not immerse the flashlight in seawater or other corrosive media as it will damage the product.
- The tail switch is magnetic, and the metal powder adsorbed on the surface will affect the function, please clean it immediately.
- Low_ON can be switched to High_ON or High_Momentary_ON; High_ON cannot be switched to Low_ON or Low_Momentary_ON.

EXCLUSION CLAUSE

Olight is not liable for damages or injuries sustained resulting from the usage of the product inconsistent with the warnings in the manual.

CONTENTS

| | |
|------------------------|----|
| (EN) English | 01 |
| (CN) 简体中文 | 01 |
| (FI) Finnish | 01 |
| (NO) Norwegian | 01 |
| (SV) Swedish | 01 |
| (NL) Nederlands | 02 |
| (PL) Polska | 02 |
| (DE) Deutsch | 02 |
| (HU) Magyarország | 02 |
| (RU) Русский | 03 |
| (ES) Español | 03 |
| (RO) Romanesc | 03 |
| (UA) Ukrainian | 03 |
| (JP) 日本語 | 04 |
| (KR) 한국어 | 04 |
| (TH) ไทย | 04 |
| (FR) Français | 04 |
| (IT) Italia | 04 |
| (SK) Slovenský jazyk | 05 |
| (PT) Português | 05 |

(EN) English

HOW TO OPERATE

Click the tail switch lightly to produce a low light output or press the tail switch hard to produce a high light output.

Single click (click and release quickly) the tail switch to turn the flashlight on or off.

When you press and hold the switch, the flashlight will be in momentary mode; when you release the tail switch, it will turn off.

(CN) 简体中文

如何操作手电

轻按输出低亮档; 重按输出高亮档;
单按 (按下并快速释放) 开启或关闭手电;
长按并保持, 手电开启, 按键释放时手电同步关闭。

(FI) Finnish

VALAISIMEN KÄYTTÖ

Käytä alhaista valotehoa painamalla kytkintä kevyesti ja korkeaa valotehoa painamalla kytkintä kovaa.

Kytke valaisin päälle ja pois päältä painamalla kytkintä kerran lyhyesti.

Käytä valaisinta hetkellisesti pitämällä kytkintä käytön ajan painettuna. Valo sammuu kun kytkin vapautetaan.

(NO) Norwegian

HVORDAN BRUKE

Klikk lett på bryteren for å produsere et svakt lys, eller trykk hardt på bryteren for høy lyseffekt.

Enkelt klikk (klikk og slipp raskt) på bryteren for å slå lommelykten av eller på.

Når du trykker og holder inne bryteren, vil lommelykten være i øyeblikkelig modus, når du slipper bryteren, vil den slå seg av.

(SV) Swedish

BYTA EFFEKTLÄGE

Klicka på knappen lätt och lampan kommer lysa med svag styrka eller klicka på knappen hårt för att lampan ska lysa med hög ljusstyrka.

Klicka en gång (tryck släpp snabbt) på knappen för att tända/släcka lampan.

När du klickar och håller ned knappen, kommer lampan tändas momentant, när du släpper knappen, slöcknar lampan.

(NL) Nederlands

HOE TE BEDIENEN

Klik zachtjes op de staartschakelaar om een laag lichtrendement te produceren of druk hard op de staartschakelaar om een hoog lichtrendement te produceren.

Eén keer klikken (snel klikken en loslaten) op de staartschakelaar om de zaklamp in of uit te schakelen.

Als u de schakelaar ingedrukt houdt, bevindt de zaklamp zich in tijdelijke modus; als u de staartschakelaar loslaat, wordt deze uitgeschakeld.

(PL) Polska

INSTRUKCJA UŻYTKOWANIA

lekko wcisnięcie tylnego przycisku spowoduje uruchomienie latarki w trybie najniższym. Mocno wcisnięcie tylnego przycisku spowoduje włączenie trybu najwyższego.

Pojedyncze wcisnięcie tylnego przycisku spowoduje włączenie lub wyłączenie latarki.

Wcisnięcie i przytrzymanie tylnego przycisku spowoduje chwilowe włączenie, puszczenie przycisku wyłączy latarkę.

(DE) Deutsch

BEDIENUNG

Durch leichtes Drücken des Endkappenschalters erhält man eine niedrige Lichtleistung, durch festeres Drücken des Endkappenschalters erhält man eine hohe Lichtleistung.

Durch einmaliges Drücken des Endkappenschalters (schnelles Klicken und Loslassen) wird die Taschenlampe an- oder ausgeschaltet.

Wenn Sie den Endkappenschalter gedrückt halten, leuchtet die Taschenlampe im Momentary Modus; Wenn Sie den Endkappenschalter loslassen, wird die Taschenlampe ausgeschaltet.

(HU) Magyarország

A HASZNÁLAT MÓDJA

Nyomja meg finoman a hátsó zárókupakon lévő kapcsolót az alacsony fényerőfokozat üzemmód kapcsolásához. A lámpa erős fényerőfokozatra kapcsolásához nyomja be teljesen a hátsó zárókupakon lévő kapcsolót.

A hátsó zárókupakon lévő kapcsoló gyors teljes benyomásával és felengedésével a lámpa bekapcsolható, illetve kikapcsolható.

A kapcsoló benyomásának és nyomva tartásának idejére a lámpa bekapcsol, majd a kapcsoló felengedésekor kikapcsol.

(RU) Русский

Инструкция

Легкое нажатие активирует режим 200 люмен, полное нажатие активирует режим 1000 люмен.

Для вкл/выкл фонаря необходимо быстро нажать и отпустить торцевую кнопку.

Если нажать и удерживать кнопку, фонарь будет гореть до тех пор, пока Вы ее не отпустите.

(ES) Español

CÓMO OPERAR

Pulse suavemente el interruptor remoto para producir poca luz de salida o pulse fuerte el interruptor remoto para producir mucha luz de salida.

Un Sólo Clic (pulse brevemente) el interruptor remoto para encender o apagar la linterna.

Quando mantiene pulsado el interruptor, la linterna estará en modo momentáneo; Cuando suelta el interruptor remoto, se apaga.

(RO) Romanesc

MOD DE OPERARE

Apasati butonul usor pentru a porni in modul mic sau apasati butonul ferm (tare) pentru a porni modul maxim.

Apasare normala (apasati scurt apoi eliberati) pentru a porni sau opri lanterna.

Atunci cand apasati si mentineti apasat butonul, lanterna va intra în mod iluminare momentan; la eliberarea butonului din spate lanterna se va stinge.

(UA) Ukrainian

Як працює

Легке натискання на торцеву кнопку вмикає економний режим яскравості; сильніше натискання переводить ліхтарик у стандартний режим світіння.

Одне швидке натискання кнопки (натисніть і одразу відпустіть) вмикає і вимикає ліхтарик.

Якщо натиснути і так утримувати кнопку, ліхтарик світитиме, і вимкнеться, якщо кнопку відпустити.

(JP) 日本語

使用方法

テールスイッチを軽く押すとLowモードで常時点灯。強く押すとHighモードで点灯します。

テールスイッチをシングルクリック (クリックして素早く離す) するとライトが点灯・消灯します。

テールスイッチを長押しすと (指はスイッチから離さないまま) ライトが点灯します、スイッチを離すと消灯します。

(KR) 한국어

작동 방법

후면 스위치를 가볍게 클릭하면 저출력 라이트가 켜지며 스위치를 끝까지 눌러주면 고풍력 라이트가 켜집니다. 1회 클릭 (손을 빠르게 놓았다 떴)으로 전원을 ON/OFF합니다. 스위치를 클릭한 채로 유지하면 라이트는 일시적으로 켜져 있고 스위치에서 손을 떼면 바로 꺼집니다.

(TH) ไทย

วิธีการควบคุมไฟฉาย

อยู่หลายโหมดจึงสามารถกำหนดได้โดยการกดสวิทช์ท้ายหนักหรือเบา สำหรับการเปิดไฟฉาย ทำได้โดยการกดสวิทช์ท้ายแล้วปล่อย ไฟฉายจะเปิด ทำอีกครั้เพื่อปิดไฟฉาย

ส่วนการเปิดหรือปิดชั่วคราว ได้โดยการกดสวิทช์ท้ายครั้งหนึ่งค้างไว้ ไฟฉายจะติด และไฟฉายจะดับเมื่อปล่อยสวิทช์ท้าย

(FR) Français

COMMENT L'UTILISER

Presser légèrement le bouton arrière pour activer le niveau de sortie faible ou presser plus fort pour activer le mode fort.

Un simple clic (presser et relâcher rapidement) allume et éteint la lampe.

Lorsque vous pressez et maintenez le bouton, la lampe s'active momentanément ; lorsque vous relâchez le bouton la lampe s'éteint.

(IT) Italia

FUNZIONAMENTO

Premere leggermente l'interruttore posteriore per produrre un'emissione di luce bassa o premere con forza l'interruttore posteriore per produrre un'elevata emissione di luce.

Con un solo clic (fare clic e rilasciare rapidamente) l'interruttore posteriore per accendere o spegnere la torcia elettrica.

Quando si tiene premuto l'interruttore, la torcia si trova in modalità momentanea; quando si rilascia l'interruttore, si spegne.

(SK) Slovenský jazyk

AKO POUŽÍVAŤ

Ľahko stlačte spínač koncovky, aby ste dosiahli slabý svetelný výkon, alebo stlačte silnejšie koncový spínač, aby ste dosiahli vysoký svetelný výkon.

Jedným kliknutím (rýchlym kliknutím a uvoľnením) koncovým spínačom zapnete alebo vypnete svetidlo.

Keď stlačíte a podržíte spínač, svetidlo bude vo chvílkovom režime; pri uvoľnení koncového spínača sa vypne.

(PT) Português

COMO OPERAR

Pressione levemente no interruptor traseiro para obter luz fraca ou pressione o interruptor traseiro com força para obter luz forte.

Pressione uma vez (pressione liberte rapidamente) o interruptor traseiro para ligar ou desligar a lanterna.

Quando mantiver o interruptor pressionado, a lanterna entra no modo momentâneo e desliga-se quando libertar o interruptor traseiro.

WARRANTY

Within 30 days of purchase: Contact the original seller for repair or replacement.

Within 5 years of purchase: Contact Olight for repair or replacement.

Battery warranty: Olight offers a one year warranty for all rechargeable batteries.

USB magnetic charging cable: One year.

For any of the fragile or low-value fittings not covered above, like wrench and self-locking bands, you can contact the post-sale within 30 days of the purchase, if it has any quality drawback or damage under normal use condition. If such drawback or damage occurs after 30 days of the purchase or under abnormal use condition, we will only offer conditional quality assurance as appropriate.

USA Customer Support

cs@olightstore.com

Global Customer Support

customer-service@olightworld.com

Visit www.olightworld.com to see our complete product line of portable illumination tools.

OLIGHT

Dongguan Olight E-Commerce Technology Co., Ltd
4th Floor, Building 4, Kegou Industrial Park, No 6 Zhongnan Road, Changan Town, Dongguan City, Guangdong, China.
Made in China

RoHS CE UK CA FC

3.4000.0460 A. 07. 30. 2022