

BATTERY INFORMATION & WARNING

Before replacing batteries, read the enclosed BATTERY INFORMATION/WARNING insert in your original packaging. For additional battery safety, handling, and product information, visit www.surefire.com/batteries.

MAINTENANCE

Use a clean, dry cloth to wipe off body and window. For additional tips on maintaining your SureFire illumination tool, visit www.surefire.com/faqs-maintenance.

ACCESSORIES

SureFire makes a full line of accessories for most of its illumination tools. For a complete listing, visit www.surefire.com/partsaccessories.

THE SUREFIRE NO-HASSLE GUARANTEE

We'll do what it takes to keep your SureFire gear running smoothly. SureFire warrants that if you — our customer — purchase one of our products, and we determine that it is defective in material and/or workmanship during your lifetime, we will repair or replace it — no hassle!

Our warranty does not cover consumables or normal wear-and-tear — things like batteries draining, headbands and headpads wearing out, ink cartridges running out, and switches wearing out — or damage resulting from abuse, alterations, unauthorized repairs, or use contrary to SureFire's user manuals.

Should you need a replacement product, SureFire reserves the right to replace an obsolete product with a current production, like model. In the event that any issue with a SureFire product is not covered under this warranty SureFire can arrange to have the product repaired for a reasonable fee.

STANDARD DISCLAIMER

Except as specified above or prohibited by applicable law: all express or implied conditions and warranties, including, without limitation, any implied warranty or condition of merchantability or fitness for a particular purpose, or accuracy of any informational content, are hereby excluded and disclaimed by SureFire; and in no event will SureFire be liable for any special, direct, indirect, consequential, incidental or punitive damages howsoever arising and regardless of the theory of liability, even if advised of the possibility of such damages. Products, prices, availability, specifications, and offers are subject to change or cancellation at any time without notice.

WARRANTY CLAIMS

For claims, contact Customer Service at 714-545-9444 to obtain a Return Merchandise Authorization number (RMA#). Then package the unit carefully and send to (no CODs):

SureFire, LLC.
Repairs Department, RMA# _____
17680 Newhope Street, Suite B
Fountain Valley, CA 92708

SureFire will pay any reasonable shipping costs to return the unit to you.

Revision E 02-2019
71-01-871
X300U-A, X300U-A-TN



X300U

ULTRA-HIGH-OUTPUT LED HANDGUN LIGHT

X300U-A
X300U-A-TN

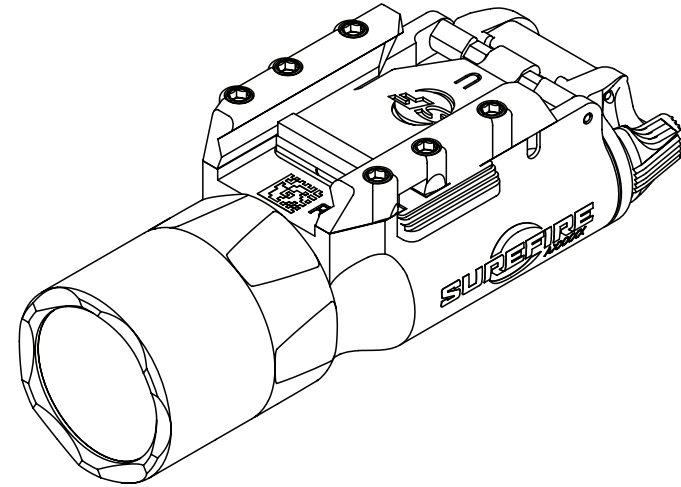

SPECIFICATIONS		X300U-A, X300U-A-TN
OUTPUT		1,000 lumens
RUNTIME		1.25 hours
PEAK BEAM INTENSITY		11,300 candela
DISTANCE		213 meters
CONSTRUCTION		Aluminum
FINISH		Mil-Spec Hard Anodized
WEIGHT (w/batteries)		4.0 oz (113 g)
LENGTH		3.6 in (9.1 cm)
BEZEL DIAMETER		1.125 in (2.9 cm)
BATTERIES		Two 123A lithium (incl.)
SWITCHING		Ambidextrous push/toggle
LIQUID INGRESS PROTECTION		IPX7, Submersion up to one meter for 30 minutes

All performance claims tested to ANSI/NEMA FL1-2009 Standard.

BEFORE INITIAL USE, REMOVE BATTERY INSULATOR



KIT CONTENTS:

- X300 ULTRA WeaponLight
- Battery Cover
- Battery Cover Retaining Pin
- Universal Lever Latch (marked “U,” installed)
- Picatinny Lever Latch (marked “P”)
- Spring (installed)
- Rail Latch Lock
- Universal Rail Latch (marked “U”)
- Picatinny Rail Latch (marked “P”)
- Lock Actuator
- Lock Actuator Screw
- 5/64” Hex Wrench
- One Tube Loctite 242
- Two 123A Batteries

BATTERY INSTALLATION / REPLACEMENT

⚠ WARNING

Use of substandard batteries can cause injury or property damage. Visit www.surefire.com/batterysafety.

1. Attach Battery Cover by aligning cover hinges with X300 ULTRA's Hinge Pin (Fig. 1) and carefully snap hinges onto pin.
2. Insert Two 123A Batteries with terminals oriented as shown in the engraved schematic on X300 ULTRA body and in Fig. 1.
3. Close Battery Cover until compartment latch clicks and locks cover in place.
4. Using pliers, insert battery cover Retaining Pin through both holes in latch bracket, as shown in Fig. 2, until pin locks in place and latch cannot be released.
5. To replace batteries, remove battery cover Retaining Pin with pliers, depress latch to open Battery Cover, and remove and properly dispose of depleted batteries.
6. Install fresh batteries and re-secure Battery Compartment per Installation directions above.

Note: Replace all batteries; never mix old and new batteries.

MOUNTING X300 ULTRA TO WEAPON

⚠ WARNING

ALWAYS confirm weapon is unloaded and on SAFE before attempting installation.

X300 ULTRA may be securely mounted to a weapon using either its Lever Latch or Rail-Lock® system. The Lever Latch system is the simpler mounting option. However, those planning on keeping their X300 mounted to their weapon fulltime may opt for Rail-Lock mounting, as it offers more security but less ease of attachment/detachment. Should your weapon experience any feed malfunctions using the Lever Latch system, they may be alleviated by switching to the Rail-Lock system. Shooter is responsible for testing, maintaining, and correctly installing any accessories to weapon.

LEVER-LATCH MOUNTING (UNIVERSAL RAILS)

X300 ULTRA ships with its Universal Lever Latch (marked “U”) pre-installed. To mount to Universal accessory rail:

1. Align X300 ULTRA Rail Guides with grooves of Universal accessory rail.
2. Slide X300 ULTRA onto rail until Lever Latch clicks and locks X300 ULTRA securely in place.
3. To remove, press down on Lever Latch tabs and slide X300 ULTRA forward off rail.

LEVER-LATCH INSTALLATION & MOUNTING (PICATINNY RAILS)

1. Using the included 5/64” Hex Wrench, remove X300 ULTRA Rail Guides by unscrewing the Hex Screws securing the Rail Guides. (Fig. 3)
2. Carefully unhook hooked end of installed Universal Lever Latch (marked “U”) from X300 ULTRA's Hinge Pin and also remove Spring underneath. (Fig. 4) Set Spring aside and store Universal Lever Latch in a secure place for future use.
3. Hook hooked end of the Picatinny Lever Latch (marked “P”) onto X300 ULTRA's Hinge Pin so “P” and SureFire logo are visible. Place Spring between Lever Latch and X300 ULTRA body so it nests in round slot on the underside of Lever Latch. (Fig. 4)
4. Apply Loctite 242 sparingly to the threads of each Hex Screw. While pressing down on Lever Latch, reattach Rail Guides by screwing in Hex Screws with Hex Wrench.
5. While holding down Lever Latch tabs, slide X300 ULTRA onto rail until Lever Latch's crossbar mates with desired rail detent, release Lever Latch tabs so that X300 ULTRA locks securely in place.
6. Remove X300 ULTRA by pushing down on Lever Latch tabs on both sides and slide X300 ULTRA off Picatinny rail.

RAIL-LOCK® INSTALLATION

1. Using the included 5/64” Hex Wrench, remove X300 ULTRA Rail Guides by unscrewing Hex Screws securing guides. (Fig. 3)
2. Carefully unhook hooked end of installed Lever Latch from X300 ULTRA's Hinge Pin and remove Lever Latch and Spring underneath it. Store both in a secure place for future use.
3. Insert Lock Actuator into slot on Rail Latch Lock, ensuring beveled side of actuator faces in (flat side out) and actuator groove is facing screw hole in the Rail Latch Lock. (Fig. 6) Insert Lock Actuator Screw into screw hole and turn

clockwise until it engages Lock Actuator. (Fig. 7)

4. Hook hooked end of Rail Latch Lock onto X300 ULTRA Hinge Pin and insert Rail Latch Lock (actuator facing down) so it fits into slot on top of X300 ULTRA body. Lock Actuator Screw may need to be loosened or tightened for screw head to align with its designated slot. (Fig. 7)
5. Select appropriate Rail Latch for weapon's rail: “U” for Universal; “P” for Picatinny.
6. Lift front edge of Rail Latch Lock. Connect slotted side of Rail Latch to front edge of Rail Latch Lock. (Fig. 6)
7. Lower Rail Latch Lock and attached Rail Latch, fitting both into their designated slots in X300 ULTRA body.
8. Apply Loctite 242 sparingly to threads of each Hex Screw, then reattach Rail Guides by screwing in Hex Screws with Hex Wrench until hand tight. One Rail Guide has a notch, which fits over the Rail Latch. (Fig. 3)

RAIL-LOCK® MOUNTING

1. Pull Rail Latch Lock tabs rearward to release Rail Latch. At the same time, pull out Rail Latch with your other hand. Extend Rail Latch as far as it will go. Do not pull too hard or extend too far—Rail Latch is not designed to come all the way out. (Fig. 8)
2. Slide X300 ULTRA onto a Universal or Picatinny rail and, once in preferred position, press in Rail Latch until it locks in place. (Fig. 9)
3. Insert 5/64” Hex Wrench into slot on side of X300 ULTRA and tighten Lock Actuator Screw.
4. To remove X300 ULTRA, loosen Lock Actuator Screw with Hex Wrench, pull back Rail Latch Lock tabs, extend Rail Latch, then slide X300 ULTRA off rail.

LIGHT OPERATION

For momentary-on light operation, press and hold either the right or left side of tailcap toggle switch; release to turn light off. (Fig. 10)

For constant-on operation, rotate tailcap toggle switch up or down; rotate in the opposite direction to turn light off. (Fig. 10)

Note: An assortment of remote switches are available for SureFire X-Series WeaponLights. Visit www.surefire.com/parts-accessories/switches.html

FIGURE 1

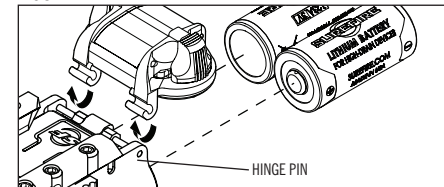

FIGURE 2

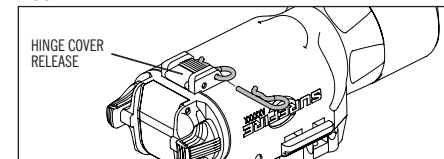

FIGURE 3

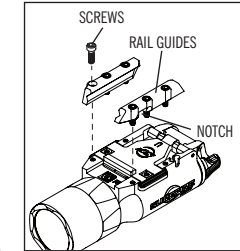

FIGURE 5

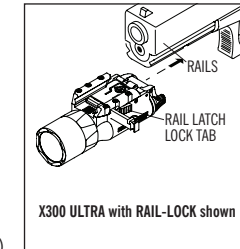

FIGURE 7

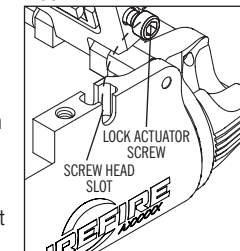

FIGURE 9

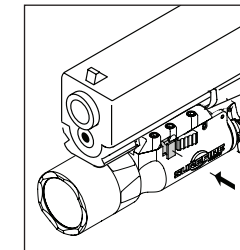

FIGURE 4

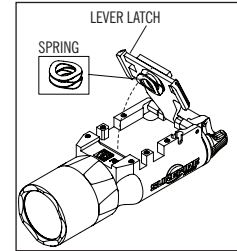

FIGURE 6

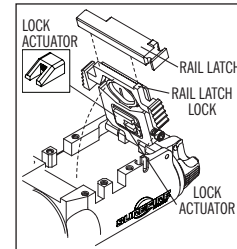

FIGURE 8

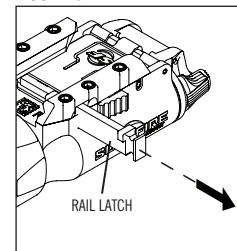

FIGURE 10

